



EAS

catalog

2018



antennas
RF technology



accessories
and tools



other products
and services

Contents

1. our company
2. antennas
 - twilight family
 - zento family
- RMS - Remote Management System
 - junior family
3. metal and magnetdetection
 - metalguard
 - hyperguard
 - apparelguard
4. drinkspector
5. accessories
- Checkout Lane Manager
6. tags and labels

Copyright © Shopguard Ltd. 2018. All rights reserved

The copyright of all content on this catalogue is owned by Shopguard Ltd. and/or the various manufacturers of our equipment. No part of the Shopguard catalog may be changed, reproduced, stored in or transmitted on any website or medium without the prior written permission of Shopguard. Requests to republish any material must be sent to marketing@shopguard.com. In case of any questions or remarks, feel free to contact us.

our company



our company

Shopguard Systems, a European private corporation, has been a leading global manufacturer of Retail Security and Merchandising Solutions for twenty-five years. We are proud to provide many of the major retailers and brands across the world with solutions that drive down shrinkage, improve store design and spark new ways to interact with customers to increase sales.

The Shopguard team currently sells into and supports customers in over 40 countries globally. Six subsidiary companies support regions and selected major markets; our network of authorized distributors and partners manage our service in other markets. Wherever our customers are they can be sure of quality, great service and quick response to their needs. That is the Shopguard brand.

As you would expect from a successful and leading company, we have won many Design and Innovation Awards and hold many patents on our unique and future-thinking solutions.

Our goal now?

Another 25 years of growth, customer appreciation and recognized innovation across the world.



what we do



Electronic Article Surveillance

EAS gate or antennas with 24/7 connectivity. We are delivering world-class and smart systems that help minimize in-store shopliftings



Drinkspector

Our unique and patented Drinkspector offers an ultimate solution for bottled liquids regardless the neck design.



Checkout Lane Management

With our CLM system long queues can be forgotten thanks to the simple idea that helps retailers with a press of a button.



Merchandising Security

We offer a wide variety of solutions. From the cutting-edge technologies to the basic and economical accessories.



Visitor Analytics

We have made an easy to use, easy to understand statistical tool for your business. If you have used Google Analytics™, then our solution will be familiar to you.

antennas



TWILIGHT FAMILY

WITH ITS TRENDY MODERN LOOK THE TWILIGHT IS CRAFTED TO COMPLEMENT THE HIGHEST STANDARD OF STORE DESIGN REQUIREMENTS.

Constructed using a premium grade German-made transparent Plexiglass body and stylish stainless steel base the Twilight also features discrete LED illumination that can be selected to compliment in-store lighting effects.



With built-in smart technology, engineered to filter out disruptive external electronic interference the Twilight provides security, good looks and outstanding detection.

Twilight is the perfect solution for retailers who want a premium looking design without sacrificing that all important detection performance.

KEY FEATURES:

- Crafted from German made Plexiglass
- Self-tuning capability testing eliminating outside electrical interferences.
- 4 LED colour illumination variations.
- TX/RX or TRX digital pulse listening system.
- 8.2 MHz based system

Two models:

- **Twilight Normal**
- **Twilight Large**



Twilight N-150 RF AFT-TRx

P0200364

General Info

Family	Twilight
Size	Normal
Type	TRx mono system

Recommendation

4x4 paper label

	metric	imperial
Norm/Max Distance*	1,6/2m	78.74in
Norm/Max On side*	0.8/1m	39.37in

Recommendation

round hardtag

	metric	imperial
Norm/Max Distance*	2,4/2,8m	110.23in
Norm/Max On side*	1,2/1,4m	55.11in

Dimension

Height	1,606m	63.23in
Width	0,328m	12.92in
Depth (thickness)	0,106m	4.17in
Approx. weight	12,2kg	26.84lbs

Electrical Requirements

PSU	18V AC	
Power Consumption	10W	
Operating Temp.	0 - 40°C	32 - 104°F

Other

Antenna Safety	CB, UL/cUL
Emissions Safety	FCC/IC, CE
Materials Used	brushed inox steel base, plexiglass body

*detection distance may vary, depends on **environment** and **tag type**.

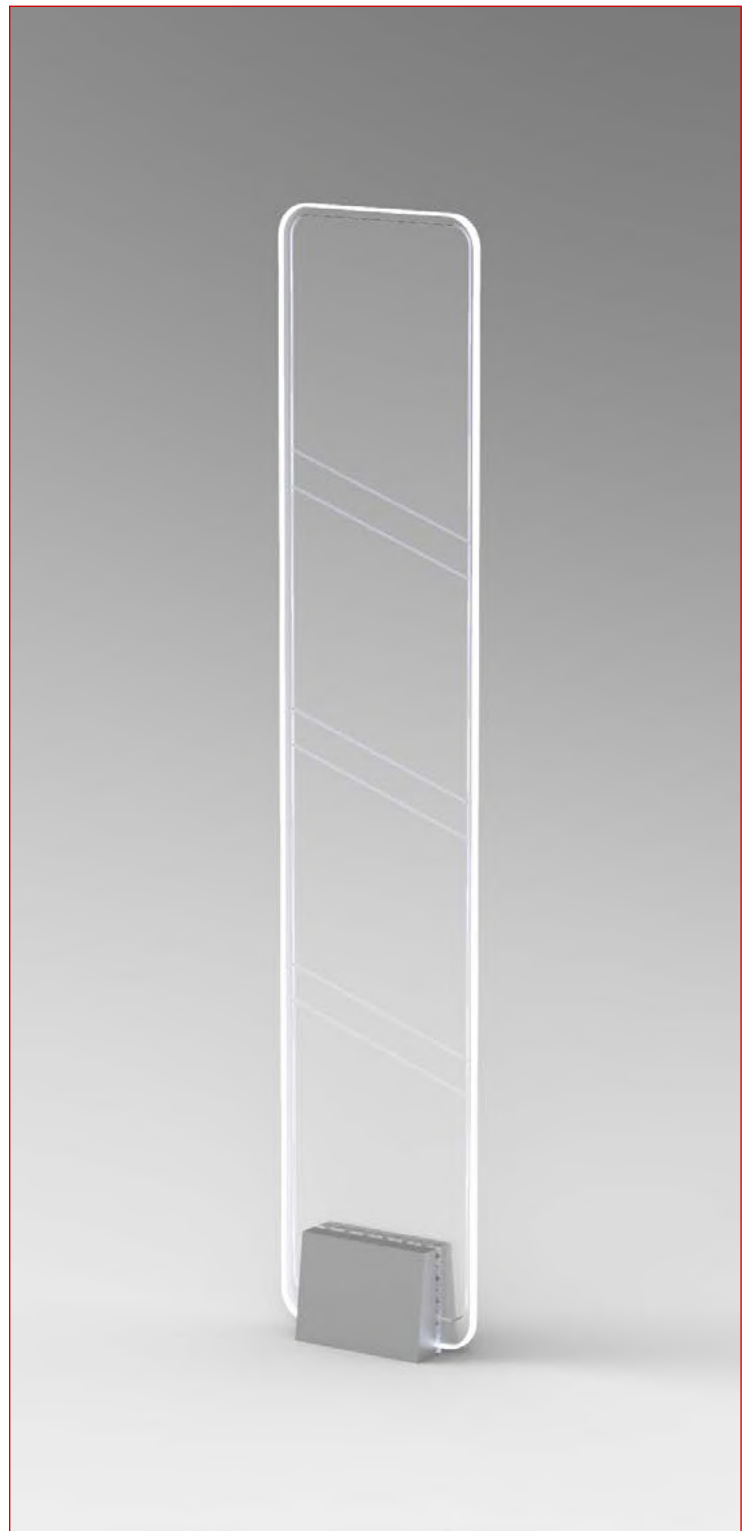

RMS
by shopguard

Available colours



white
red on alarm

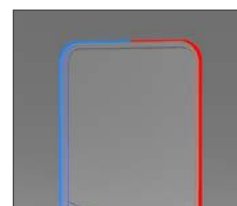

blue
red on alarm

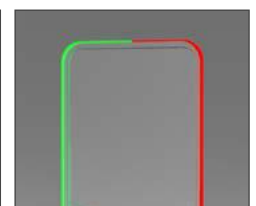

green
red on alarm

Tx/Rx duo

TRx Alternating Field

Twilight N-150 Tx/Rx

P0200031 / P0200035

General Info

Family	Twilight
Size	Normal
Type	Tx / Rx system

Recommendation

4x4 paper label

	metric	imperial
Norm/Max Distance*	2,6/3m	102/118in
Norm/Max On side*	1,3/1,5m	51/59in

Recommendation

round hardtag

	metric	imperial
Norm/Max Distance*	2,4/3,8m	94/150in
Norm/Max On side*	1,7/1,9m	67/75in

Dimension

Height	1,606m	63.23in
Width	0,328m	12.92in
Depth (thickness)	0,106m	4.17in
Approx. weight	12,2kg	26.84lbs

Electrical Requirements

PSU	24V DC	
Power Consumption	4W/16,5W	
Operating Temp.	0 - 40 °C	32 - 104 °F

Other

Antenna Safety	CB, UL/cUL
Emissions Safety	FCC/IC, CE
Materials Used	brushed inox steel base, plexiglass body

*detection distance may vary, depends on **environment** and **tag type**.

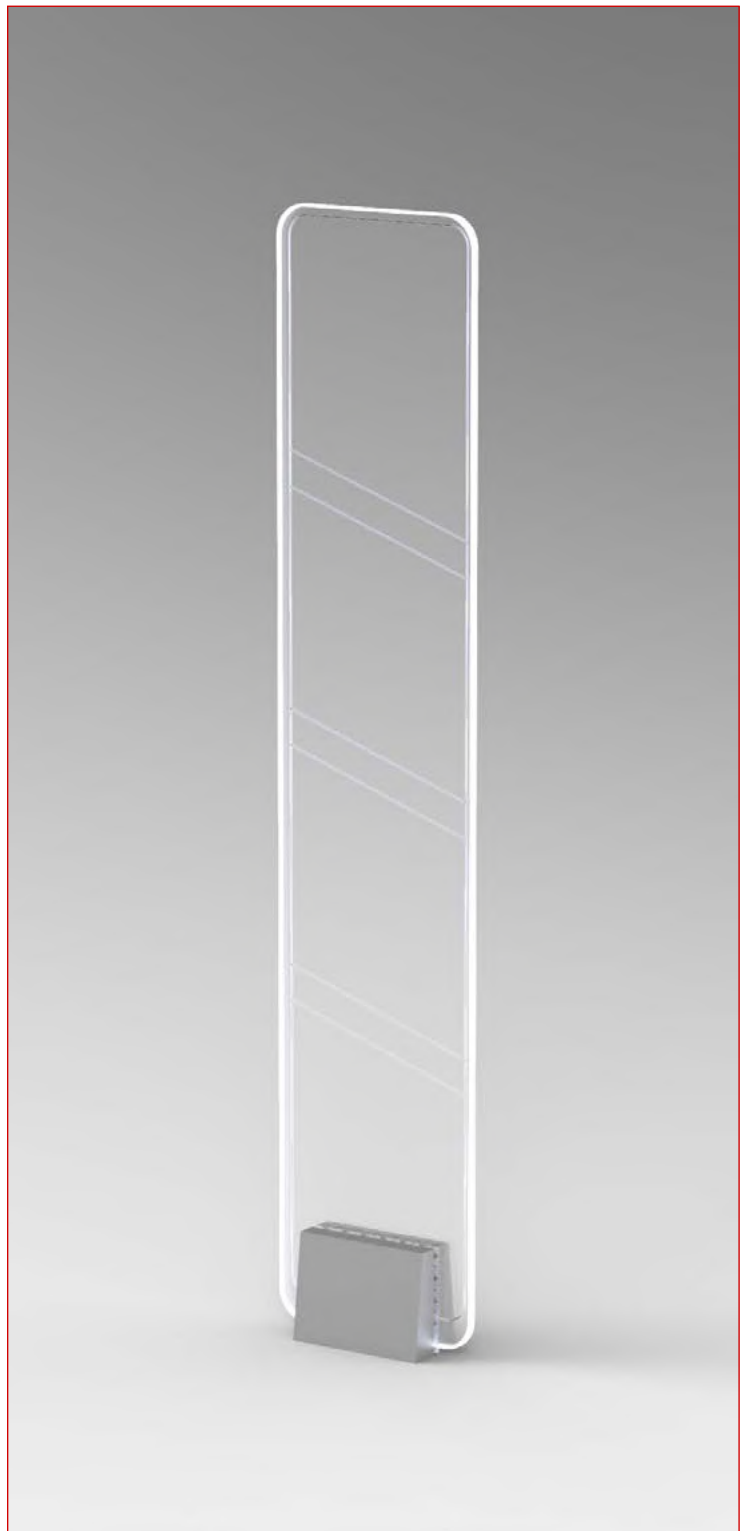

Available colours

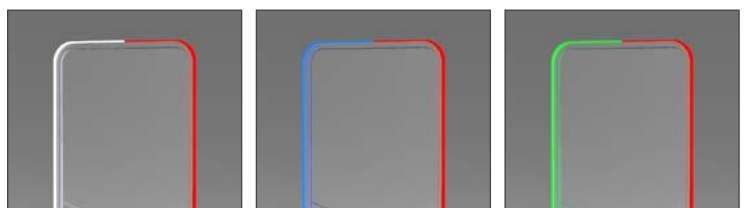

white
red on alarm

blue
red on alarm

green
red on alarm

Tx/Rx duo

TRx Alternating Field

Twilight L-150

RF AFT-TRx

P0200365

General Info

Family	Twilight
Size	Large
Type	TRx mono system

Recommendation

4x4 paper label

	metric	imperial
Norm/Max Distance*	1,8/2,2m	71/86in
Norm/Max On side*	0,9/1,1m	35/43in

Recommendation

round hardtag

	metric	imperial
Norm/Max Distance*	2,6/3m	102/118in
Norm/Max On side*	1,3/1,5m	51/59in

Dimension

Height	1,606m	63.23in
Width	0,428m	16.73in
Depth (thickness)	0,106m	4.17in
Approx. weight	13,8kg	30.36lbs

Electrical Requirements

PSU	18V AC	
Power Consumption	10W	
Operating Temp.	0 - 40 °C	32 - 104 °F

Other

Antenna Safety	CB, UL/cUL
Emissions Safety	FCC/IC, CE
Materials Used	brushed inox steel base, plexiglass body

*detection distance may vary, depends on **environment** and **tag type**.

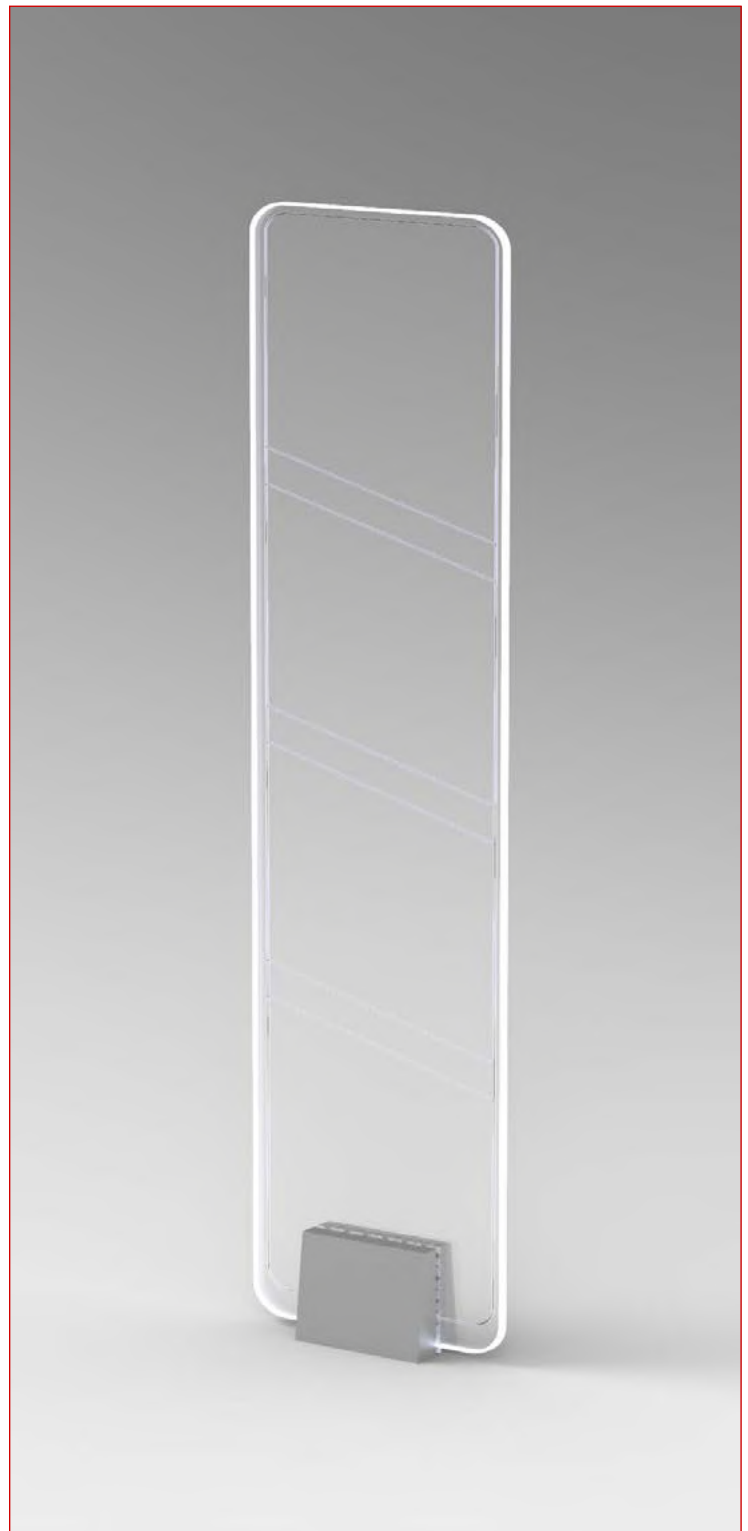

RMS
by shopguard

Available colours



white
red on alarm

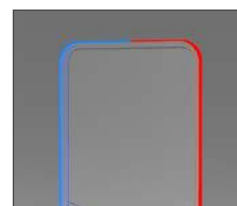

blue
red on alarm

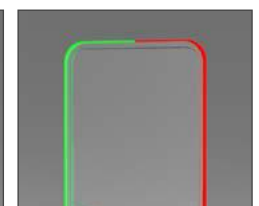

green
red on alarm

Tx/Rx duo

TRx Alternating Field

Connect to antennas online with RMS

A wirelessly interconnected antenna system without the need for local service

- immediate service response
- lower number of onsite maintenance
- uninterrupted business
- remote customization (for TRX only)

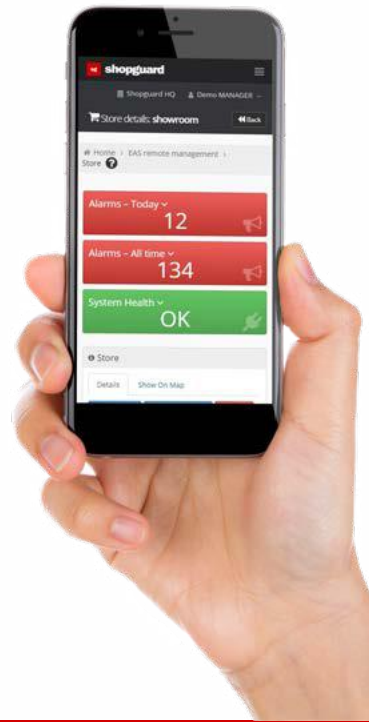

for more info visit our website www.shopguard.com

Diagnostics and Analytics



ZENTO FAMILY

THE ZENTO IS ONE OF OUR MOST POPULAR SECURITY GATES, TRIED AND TRUSTED IN THOUSANDS OF RETAIL OUTLETS IN EUROPE AND AROUND THE GLOBE.

The Zento is an extruded aluminium lightweight yet robust antenna, perfectly matching to your store interior and non-obtrusively fulfilling its task.

Designed with maximum transparency, minimising entrance obstruction yet offers maximum detection of hard tags and disposable tags in challenging store environments.



The Zento is available in **RF** with TX/RX and TRX versions, with PC connection and remote monitoring available for TRXs.



ZENTO FAMILY (DISTANCE DATA BETWEEN ANTENNAS)



	# Product No.	TRx mono	Shield on side	Detection 4x4 paper label (normal/max)		Detection round hardtag (normal/max)	
L-Line (Large)							
Zento L-150 RF AFT-TRx	P0200352	yes		2/2,4m	78/94in	2,4/2,8m	78/110in
Zento L-170 RF AFT-TRx	P0200349	yes		2/2,4m	78/94in	2,4/3m	94/118in
Zento L-150 RF Tx/Rx	P0200291/*2			3/3,4m	118/134in	3,8/4,2m	150/165in
N-Line (Normal)							
Zento N-150 Light RF AFT-TRx	P0200389	yes		1,8/2,2m	70/86in	2,2/2,6m	86/102in
Zento N-150 RF Tx/Rx	P0200297/*8			2,8/3,2m	110/126in	3,6/4m	140/157in
Zento N-150 RF AFT-TRx	P0200353	yes		1,8/2,2m	70/86in	2,2/2,6m	86/102in
S-Line (Slim)							
Zento S-170 RF AFT-TRx	P0200368	yes		1,2/1,6m	47/62in	1,6/2m	62/78in
Zento S-170 RF AFT-TRX ISSH	P0200367	yes	yes	1,1/1,5m	43/59in	1,4/1,8m	55/70in



ADVERTISING INSERT SIZE

	# Product No.	Height	visible height	Width	visible width
L-Line (Large)					
Zento L-150 RF AFT-TRx	P0200352	1265mm	1246mm	450mm	434mm
Zento L-170 RF AFT-TRx	P0200349	1465mm	1446mm	450mm	434mm
Zento L-150 RF Tx/Rx	P0200291/*2	1265mm	1246mm	450mm	434mm
N-Line (Normal)					
Zento N-150 Light RF AFT-TRx	P0200389	1228mm	1208mm	350mm	334mm
Zento N-150 RF Tx/Rx	P0200297/*8	1265mm	1246mm	350mm	334mm
Zento N-150 RF AFT-TRx	P0200353	1265mm	1246mm	350mm	334mm
S-Line (Slim)					
Zento S-170 RF AFT-TRx	P0200368	1410mm	1391mm	250mm	234mm
Zento S-170 RF AFT-TRX ISSH	P0200367	1410mm	1391mm	250mm	234mm



Zento L-150 RF AFT-TRx

P0200352

General Info	
Family	Zento
Size	Large
Type	TRx mono system

Recommendation 4x4 paper label	metric	imperial
Norm/Max Distance*	2/2,4m	78/94in
Norm/Max On side*	1/1,2m	39/47in
Recommendation round hardtag	metric	imperial
Norm/Max Distance*	2,4/2,8m	78/110in
Norm/Max On side*	1,2/1,4m	47/55in
Dimension		
Height	1,526m	60in
Width	0,511m	20in
Depth (thickness)	0,061m	2.4in
Approx. weight	8,9kg	19.58lbs

Electrical Requirements		
PSU	18V AC	
Power Consumption	7W	
Operating Temp.	0 - 40 °C	32 - 104 °F

Other	
Antenna Safety	CB, UL/cUL
Emissions Safety	FCC/IC, CE
Materials Used	aluminium side, plastic insert and body

*detection distance may vary, depends on **environment** and **tag type**.



RMS
by shopguard

Tx/Rx duo

TRx Alternating Field



Available colours



white

Zento L-170 RF AFT-TRx

P0200349

General Info

Family	Zento
Size	Large
Type	TRx mono system

Recommendation

4x4 paper label

	metric	imperial
Norm/Max Distance*	2/2,4m	78/94in
Norm/Max On side*	1/1,2m	39/47in

Recommendation

round hardtag

	metric	imperial
Norm/Max Distance*	2,4/3m	94/118in
Norm/Max On side*	1,2/1,5m	47/59in

Dimension

Height	1,726m	68in
Width	0,511m	20in
Depth (thickness)	0,061m	2.4in
Approx. weight	12kg	26.4lbs

Electrical Requirements

PSU	18V AC	
Power Consumption	7W	
Operating Temp.	0 - 40 °C	32 - 104 °F

Other

Antenna Safety	CB, UL/cUL
Emissions Safety	FCC/IC, CE
Materials Used	aluminium side, plastic insert and body

*detection distance may vary, depends on **environment** and **tag type**.



Available colours

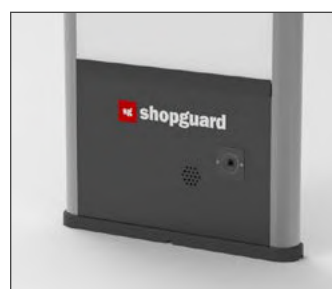

dark grey

Tx/Rx duo

TRx Alternating Field

Zento L-150 RF Tx/Rx

P0200291 / P0200292

General Info

Family	Zento
Size	Large
Type	TRx mono system

Recommendation 4x4 paper label

	metric	imperial
Norm/Max Distance*	3/3,4m	118/134in
Norm/Max On side*	1,5/1,7m	59/67in

Recommendation round hardtag

	metric	imperial
Norm/Max Distance*	3,8/4,2m	150/165in
Norm/Max On side*	1,9/2,1m	74/82in

Dimension

Height	1,526m	60in
Width	0,511m	20in
Depth (thickness)	0,061m	2.4in
Approx. weight	9,2kg	20.24lbs

Electrical Requirements

PSU	24V DC	
Power Consumption	4W/16,5W	
Operating Temp.	0 - 40 °C	32 - 104 °F

Other

Antenna Safety	CB, UL/cUL
Emissions Safety	FCC/IC, CE
Materials Used	aluminium side, plastic insert and body

*detection distance may vary, depends on **environment** and **tag type**.



Available colours



white

Tx/Rx duo

TRx Alternating Field

Zento N-150 Light RF AFT-TRx

P0200389

General Info	
Family	Zento
Size	Normal
Type	TRx mono system

Recommendation 4x4 paper label	metric	imperial
Norm/Max Distance*	1,8/2,2m	70/86in
Norm/Max On side*	9/1,1m	35/43in
Recommendation round hardtag	metric	imperial
Norm/Max Distance*	2,2/2,6m	86/102in
Norm/Max On side*	1,1/1,3m	43/51in
Dimension		
Height	1,526m	60in
Width	0,411m	16.2in
Depth (thickness)	0,061m	2.4in
Approx. weight	9,2kg	20.24lbs

Electrical Requirements		
PSU	18V AC	
Power Consumption	7W	
Operating Temp.	0 - 40 °C	32 - 104 °F

Other	
Antenna Safety	CB, UL/cUL
Emissions Safety	FCC/IC, CE
Materials Used	aluminium side, plastic insert and body

*detection distance may vary, depends on **environment** and **tag type**.



Tx/Rx duo

TRx Alternating Field



Available colours



light grey

Zento N-150 RF Tx/Rx

P0200297 / P0200298

General Info	
Family	Zento
Size	Normal
Type	Tx / Rx system

Recommendation 4x4 paper label	metric	imperial
Norm/Max Distance*	2,8/3,2m	110/126in
Norm/Max On side*	1,4/1,6m	55/63in
Recommendation round hardtag	metric	imperial
Norm/Max Distance*	3,6/4m	140/157in
Norm/Max On side*	1,8/2m	70/78in
Dimension		
Height	1,526m	60in
Width	0,411m	16.2in
Depth (thickness)	0,061m	2.4in
Approx. weight	7,7kg	17lbs

Electrical Requirements		
PSU	24V DC	
Power Consumption	4W/16,5W	
Operating Temp.	0 - 40 °C	32 - 104 °F

Other	
Antenna Safety	CB, UL/cUL
Emissions Safety	FCC/IC, CE
Materials Used	aluminium side, plastic insert and body

*detection distance may vary, depends on **environment** and **tag type**.



Available colours



white

Tx/Rx duo

TRx Alternating Field

Zento N-150 RF AFT-TRx

P0200353

General Info	
Family	Zento
Size	Normal
Type	TRx mono system

Recommendation 4x4 paper label	metric	imperial
Norm/Max Distance*	1,8/2,2m	70/86in
Norm/Max On side*	0,9/1,1m	35/43in
Recommendation round hardtag	metric	imperial
Norm/Max Distance*	2,2/2,6m	86/102in
Norm/Max On side*	1,1/1,3m	43/51in
Dimension		
Height	1,526m	60in
Width	0,411m	16.2in
Depth (thickness)	0,061m	2.4in
Approx. weight	8kg	17.6lbs

Electrical Requirements		
PSU	18V AC	
Power Consumption	7W	
Operating Temp.	0 - 40 °C	32 - 104 °F

Other	
Antenna Safety	CB, UL/cUL
Emissions Safety	FCC/IC, CE
Materials Used	aluminium side, plastic insert and body

*detection distance may vary, depends on **environment** and **tag type**.



RMS
by shopguard

Tx/Rx duo

TRx Alternating Field



Available colours



white

Zento S-170 RF AFT-TRx

P0200368

General Info

Family	Zento
Size	Slim
Type	TRx mono system

Recommendation 4x4 paper label

	metric	imperial
Norm/Max Distance*	1,2/1,6m	47/62in
Norm/Max On side*	0,6/0,8m	23/31in

Recommendation round hardtag

	metric	imperial
Norm/Max Distance*	1,6/2m	62/78in
Norm/Max On side*	0,8/1m	31/39in

Dimension

Height	1,726m	68in
Width	0,311m	12.2in
Depth (thickness)	0,061m	2.4in
Approx. weight	8,3kg	18,26lbs

Electrical Requirements

PSU	18V AC	
Power Consumption	7W	
Operating Temp.	0 - 40 °C	32 - 104 °F

Other

Antenna Safety	CB, UL/cUL
Emissions Safety	FCC/IC, CE
Materials Used	aluminium side, plastic insert and body

*detection distance may vary, depends on **environment** and **tag type**.



Available colours



dark grey

Tx/Rx duo

TRx Alternating Field

Zento S-170 RF AFT-TRX ISSH

P0200367

General Info	
Family	Zento
Size	Slim (Internal Slim Shielded)
Type	TRx mono system

Recommendation 4x4 paper label	metric	imperial
Norm/Max Distance*	1,1/1,5m	43/59in
Norm/Max On side*	shielded	shielded
Recommendation round hardtag	metric	imperial
Norm/Max Distance*	1,4/1,8m	55/70in
Norm/Max On side*	shielded	shielded
Dimension		
Height	1,726m	68in
Width	0,311m	12.2in
Depth (thickness)	0,061m	2.4in
Approx. weight	13,8kg	30.36lbs

Electrical Requirements		
PSU	18V AC	
Power Consumption	7W	
Operating Temp.	0 - 40 °C	32 - 104 °F

Other	
Antenna Safety	CB, UL/cUL
Emissions Safety	FCC/IC, CE
Materials Used	aluminium side, plastic insert and body

*detection distance may vary, depends on **environment** and **tag type**.



Available colours

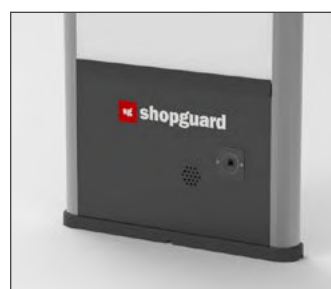

dark grey



RMS
by shopguard

Tx/Rx duo

TRx Alternating Field

Integrated Cashier Antenna RF AFT-TRx

Contact us!

General Info	
Family	Other
Type	TRx system with shield on one side (on cashier side)

Recommendation 4x4 paper label	metric	imperial
Norm/Max Distance*	1,6/2m	78.74in
Norm/Max On side*	0.8/1m	39.37in
Recommendation round hardtag	metric	imperial
Norm/Max Distance*	2,4/2,8m	110.23in
Norm/Max On side*	1,2/1,4m	47.24in

Custom made!

Contact us for further info!

Dimension		
Height	1,606m	63.23in
Width	0,328m	12.92in
Depth (thickness)	0,106m	4.17in
Approx. weight	12,2kg	26.84lbs

Electrical Requirements		
PSU	18V AC	
Power Consumption	10W	
Operating Temp.	0 - 40 °C	32 - 104 °F

Other	
Antenna Safety	CB, UL/cUL
Emissions Safety	FCC/IC, CE
Materials Used	steel frame, plastic body

*detection distance may vary, depends on **environment** and **tag type**.



Tx/Rx duo

TRx Alternating Field

JUNIOR FAMILY

JUNIOR IS ONE OF THE MOST SUCCESSFUL ANTENNA OF SHOPGUARD THANKS TO ITS RELIABILITY AND VERSATILITY. PRICEWISE IT IS SIMPLY UNBEATABLE. AVAILABLE IN TX-RX AND TRX VERSIONS.

All the major tags and accessories are compatible with the product:

- hard tags
- ink tags
- soft tags, paper labels
- safers
- detaching and deactivator products
- spider wraps

BENEFITS

- fits to any entrance and cashier size
- durable body (steel tube)
- simple and clean “see-through” design
- audible and visible alarm and feedback
- floor antenna can be controlled by it



Junior RF AFT-TRX

P0200011

General Info	
Family	Junior
Size	Normal
Type	TRx mono system

Recommendation 4x4 paper label	metric	imperial
Norm/Max Distance*	1,6/2m	62/78in
Norm/Max On side*	0,8/1m	31/39in
Recommendation round hardtag	metric	imperial
Norm/Max Distance*	2,2/2,6m	86/102in
Norm/Max On side*	1,1/1,3m	43/51in
Dimension		
Height	1,622m	64in
Width	0,355m	14in
Depth (thickness)	0,083m	3.3in
Approx. weight	7,5kg	16.5lbs

Electrical Requirements		
PSU	18V AC	
Power Consumption	7W	
Operating Temp.	0 - 40 °C	32 - 104 °F

Other	
Antenna Safety	CB, UL/cUL
Emissions Safety	FCC/IC, CE
Materials Used	Steel body, plastic housing

*detection distance may vary, depends on **environment** and **tag type**.



Tx/Rx duo

TRx Alternating Field

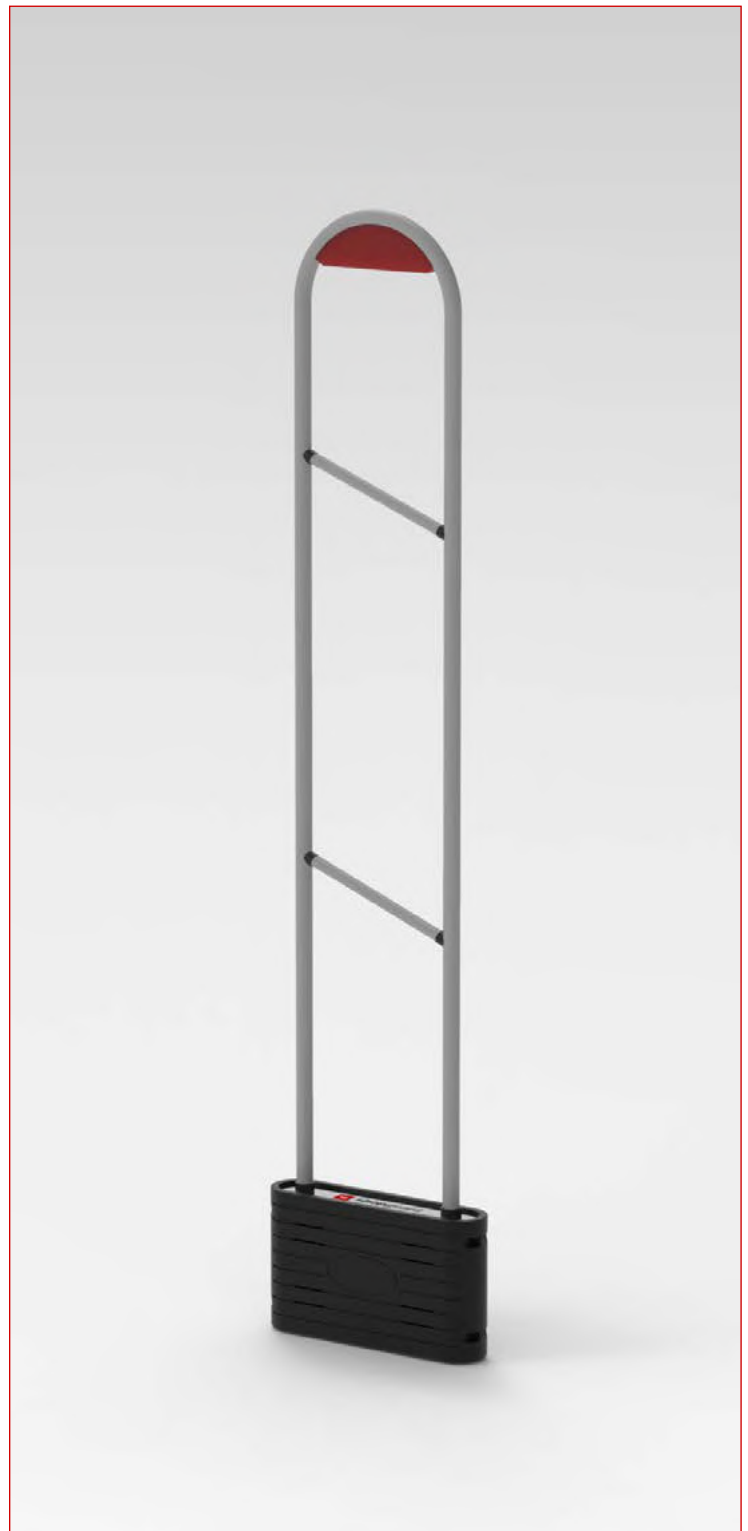

Available colours



silver

anthracite

black

Junior RF Tx / Rx

P0200009 / P0200010

General Info

Family	Junior
Size	Normal
Type	Tx / Rx system

Recommendation

4x4 paper label

	metric	imperial
Norm/Max Distance*	2,6/3m	102/118in
Norm/Max On side*	1,3/1,5m	51/59in

Recommendation

round hardtag

	metric	imperial
Norm/Max Distance*	2,4/3,8m	94/150in
Norm/Max On side*	1,7/1,9m	47/75in

Dimension

Height	1,622m	64in
Width	0,355m	14in
Depth (thickness)	0,083m	3.3in
Approx. weight	8kg	17.6lbs

Electrical Requirements

PSU	18V AC	
Power Consumption	520mA / 9,36W	
Operating Temp.	0 - 40 °C	32 - 104 °F

Other

Antenna Safety	CB, UL/cUL
Emissions Safety	FCC/IC, CE
Materials Used	Steel body, plastic housing

*detection distance may vary, depends on **environment** and **tag type**.



Available colours



silver

anthracite

black

Tx/Rx duo

TRx Alternating Field

Metal and Magnetdetection

Metalguard, Hyperguard, Apparelguard

LATEST TECHNOLOGY AGAINST BOOSTER BAGGING
AND ILLEGAL MAGNET USE



metalguard | hyperguard | apparelguard

All 3 products utilizes same software and hardware technology platform.
This means that both controllers and antennas are very similar, and all products are CE, UL, FCC, IC.

	metalguard	hyperguard	apparelguard
Metal detection	✓	✓	
Door filter (patented)	✓	✓	
Trolley filter (patented)		✓	
Magnet detection (patented)			✓
Cat5e cables included	✓	✓	
Adjustable software	✓	✓	✓
RF integration	✓	✓	
Controller box	✓	✓	✓
11 unit power-up with one CB	✓	✓	✓
API for EAS antennas	✓	✓	✓
CE, UL, FCC, IC.	✓	✓	✓
RF & AM compatible	✓	✓	✓



Apparelguard

General Info

Family	Apparelguard
Type	magnet detection

Recommendation

	metric	imperial
Max Distance	1,4m	55in

Dimension

Height	235mm	9.2in
Width	130mm	5.1in
Depth (thickness)	28mm	1.1in
Approx. weight	1,5kg	3.3lbs

Electrical Requirements

PSU	from control box	
Power Consumption	NA	
Operating Temp.	0 - 40 °C	32 - 104 °F

Other

Antenna Safety	CB, UL/cUL	
Emissions Safety	FCC/IC, CE	
Materials Used	Steel bottom, plexi body	

*detection distance may vary, depends on **environment** and **tag type**.



**to prevent the use of illegal magnets
with adjustable sensitivity**

Metalguard 12cm

General Info	
Family	Metalguard
Size	12cm
Type	metal detection

Recommendation	metric	imperial
Max Distance	2m	78in
Dimension		
Height	1,51m	59in
Width	0,12m	4.7in
Depth (thickness)	0,011m	0.43in
Approx. weight	6,4kg	14lbs

Electrical Requirements		
PSU	from control box	
Power Consumption	NA	
Operating Temp.	0 - 40 °C	32 - 104 °F

Other	
Antenna Safety	CB, UL/cUL
Emissions Safety	FCC/IC, CE
Materials Used	Steel bottom, plexi body

*detection distance may vary, depends on **environment** and **tag type**.

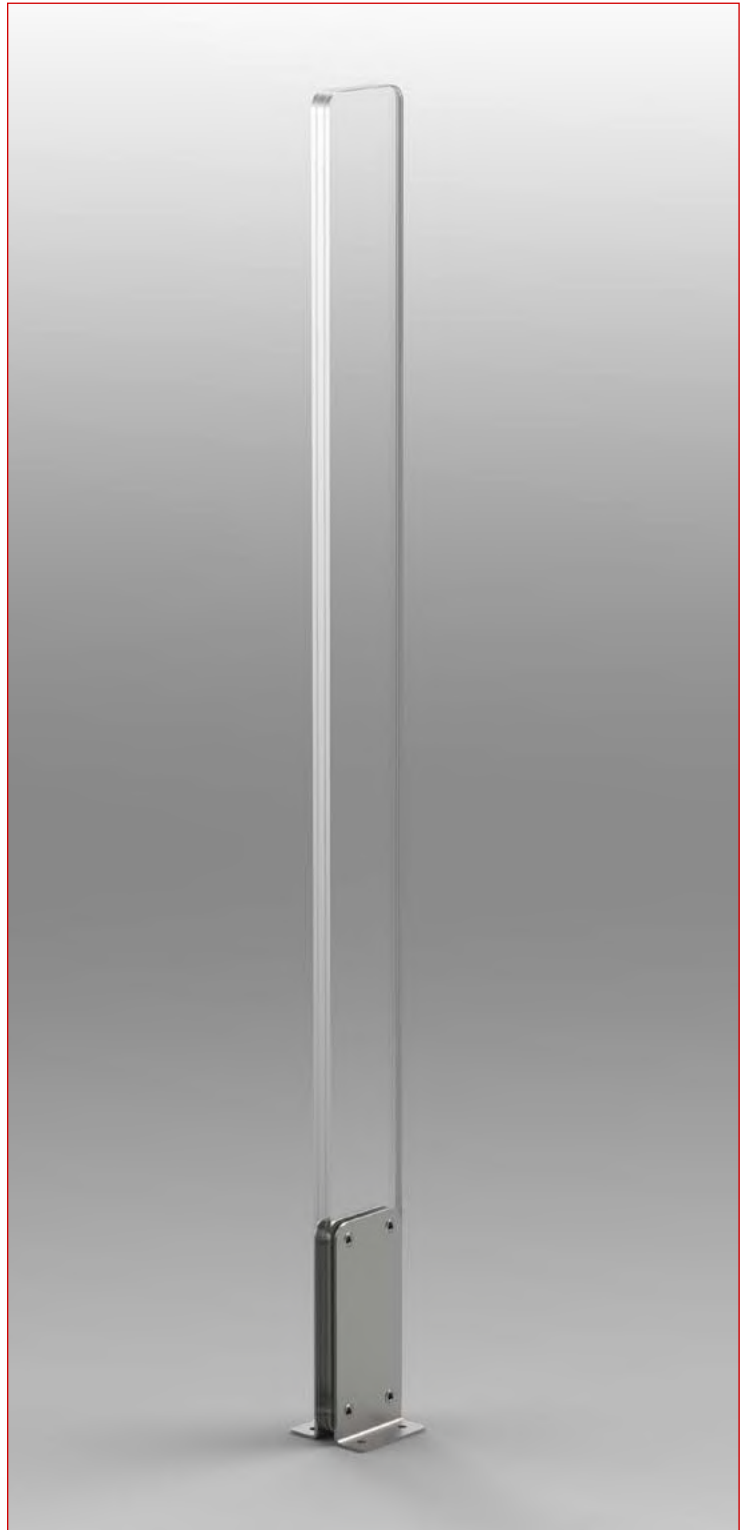

Compatible with all of our antennas and other
manufacturers' systems

The best tool against booster bagging

Metalguard 18cm

General Info

Family	Metalguard
Size	18cm
Type	metal detection

Recommendation

	metric	imperial
Max Distance	2,4m	94.5in

Dimension

Height	1,51m	59in
Width	0,18m	7in
Depth (thickness)	0,011m	0.43in
Approx. weight	10kg	22lbs

Electrical Requirements

PSU	from control box	
Power Consumption	NA	
Operating Temp.	0 - 40 °C	32 - 104 °F

Other

Antenna Safety	CB, UL/cUL	
Emissions Safety	FCC/IC, CE	
Materials Used	Steel bottom, plexi body	

*detection distance may vary, depends on **environment** and **tag type**.

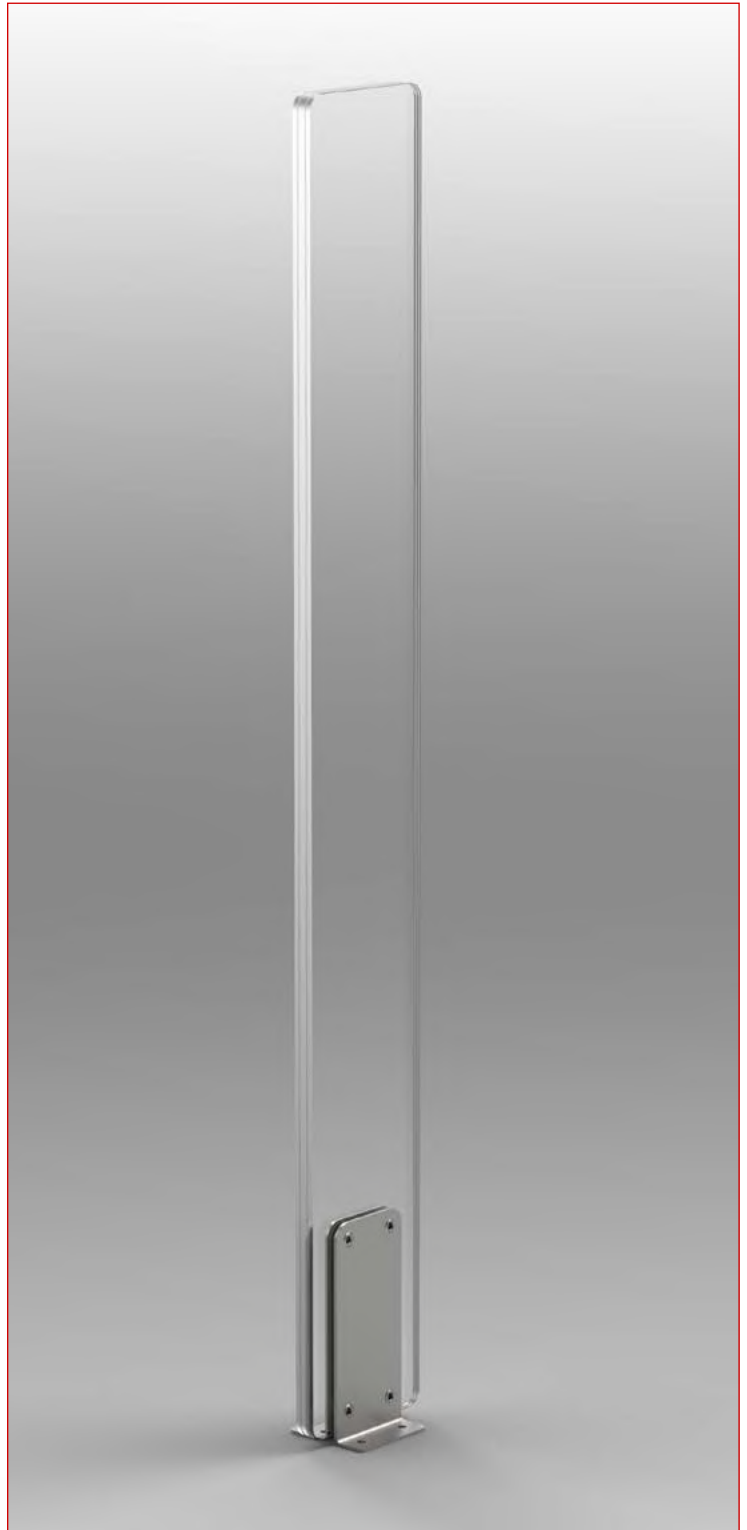

Compatible with all of our antennas and other
manufacturers' systems

The best tool against booster bagging

Metalguard 24cm

General Info

Family	Metalguard
Size	24cm
Type	metal detection

Recommendation

	metric	imperial
Max Distance	3m	118in

Dimension

Height	1,51m	59in
Width	0,24m	9.4in
Depth (thickness)	0,011m	0.43in
Approx. weight	13,6kg	30lbs

Electrical Requirements

PSU	from control box	
Power Consumption	NA	
Operating Temp.	0 - 40 °C	32 - 104 °F

Other

Antenna Safety	CB, UL/cUL	
Emissions Safety	FCC/IC, CE	
Materials Used	Steel bottom, plexi body	

*detection distance may vary, depends on **environment** and **tag type**.

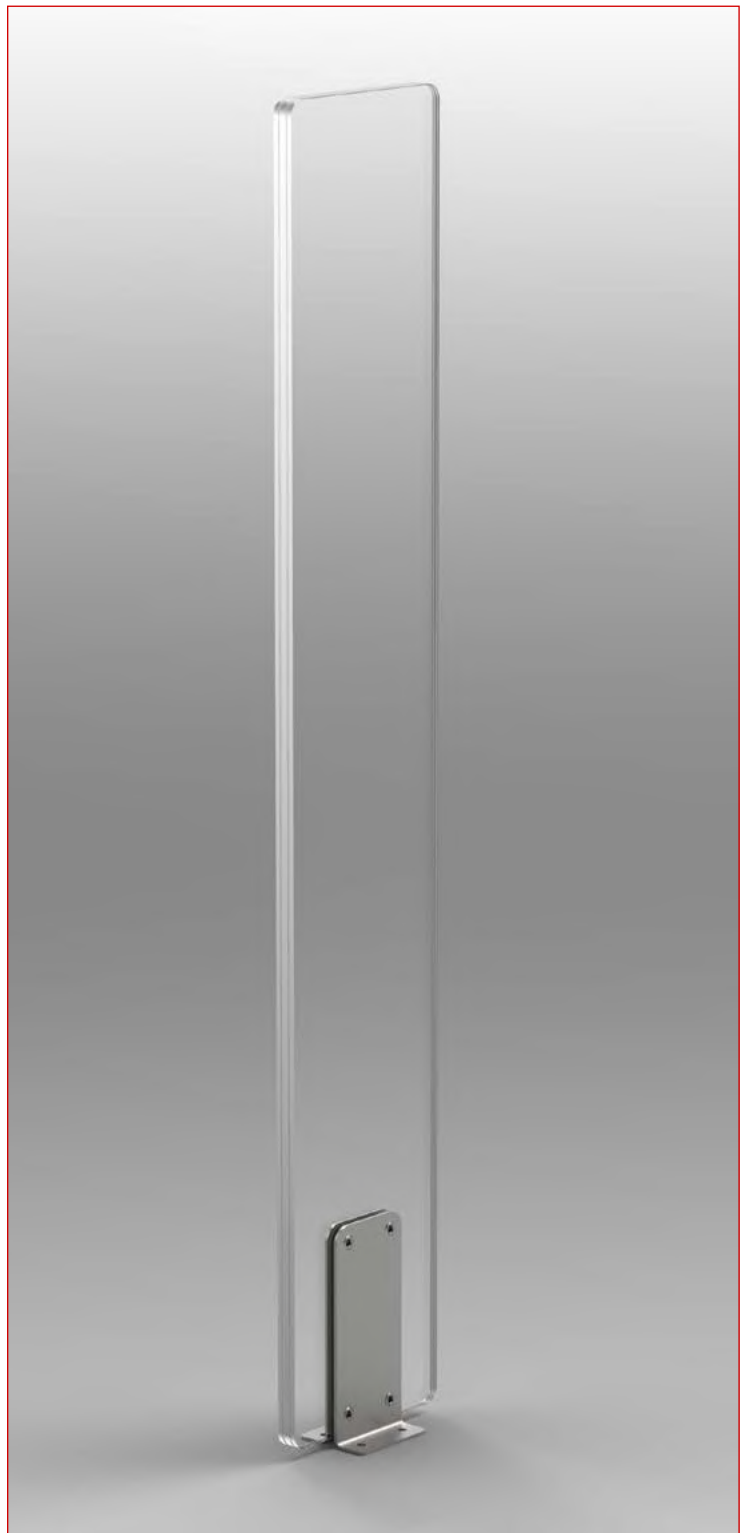

Compatible with all of our antennas and other
manufacturers' systems

The best tool against booster bagging

Hyperguard 12cm

General Info	
Family	Metalguard
Size	12cm
Type	metal detection

Recommendation	metric	imperial
Max Distance	2m	78in
Dimension		
Height	1,51m	59in
Width	0,12m	4.7in
Depth (thickness)	0,011m	0.43in
Approx. weight	6,4kg	14lbs

Electrical Requirements		
PSU	from control box	
Power Consumption	NA	
Operating Temp.	0 - 40 °C	32 - 104 °F

Other	
Antenna Safety	CB, UL/cUL
Emissions Safety	FCC/IC, CE
Materials Used	Steel bottom, plexi body

*detection distance may vary, depends on **environment** and **tag type**.

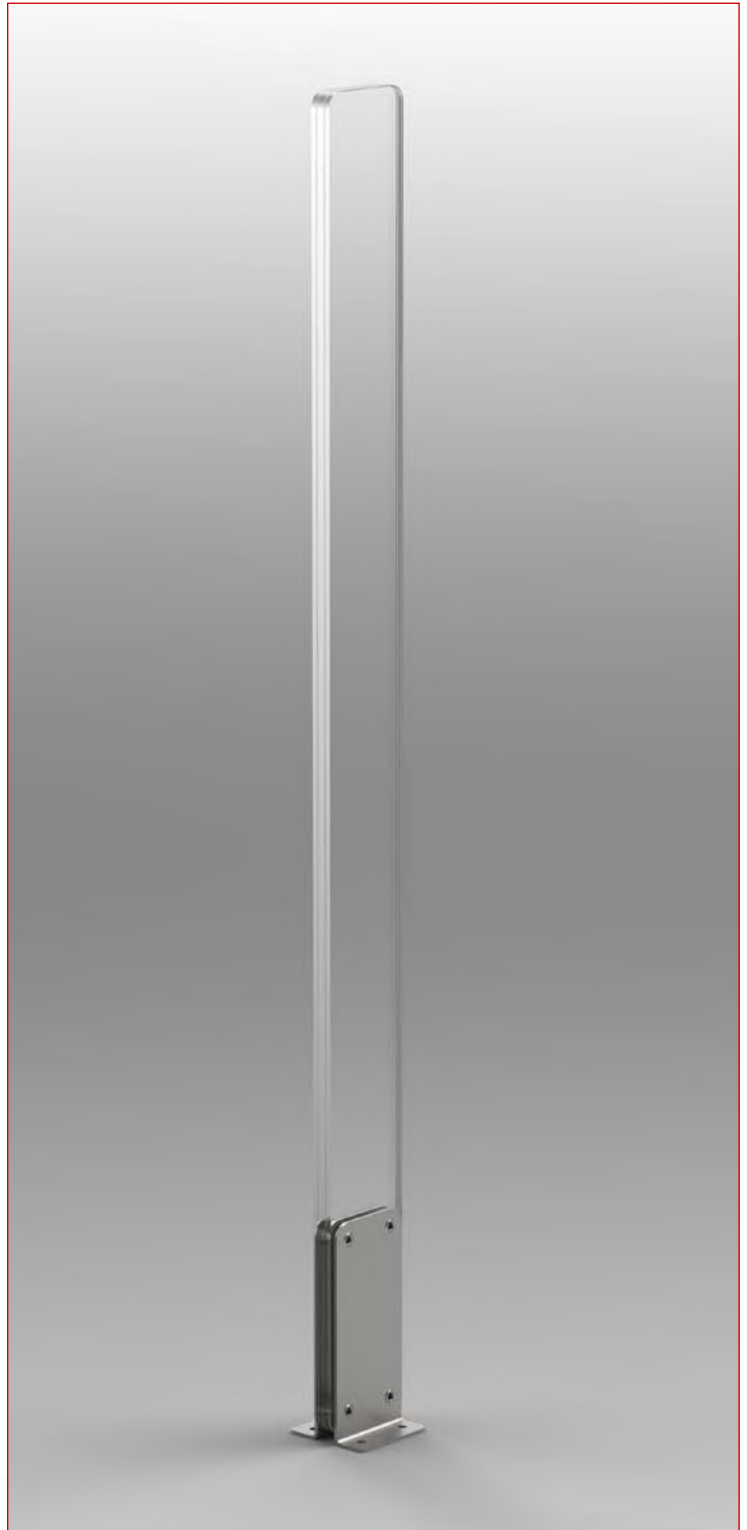

Compatible with all of our antennas and other manufacturers' systems

The best tool against booster bagging with trolley-filter



Hyperguard 18cm

General Info	
Family	Metalguard
Size	18cm
Type	metal detection

Recommendation	metric	imperial
Max Distance	2,4m	94.5in
Dimension		
Height	1,51m	59in
Width	0,18m	7in
Depth (thickness)	0,011m	0.43in
Approx. weight	10kg	22lbs

Electrical Requirements		
PSU	from control box	
Power Consumption	NA	
Operating Temp.	0 - 40 °C	32 - 104 °F

Other	
Antenna Safety	CB, UL/cUL
Emissions Safety	FCC/IC, CE
Materials Used	Steel bottom, plexi body

*detection distance may vary, depends on **environment** and **tag type**.

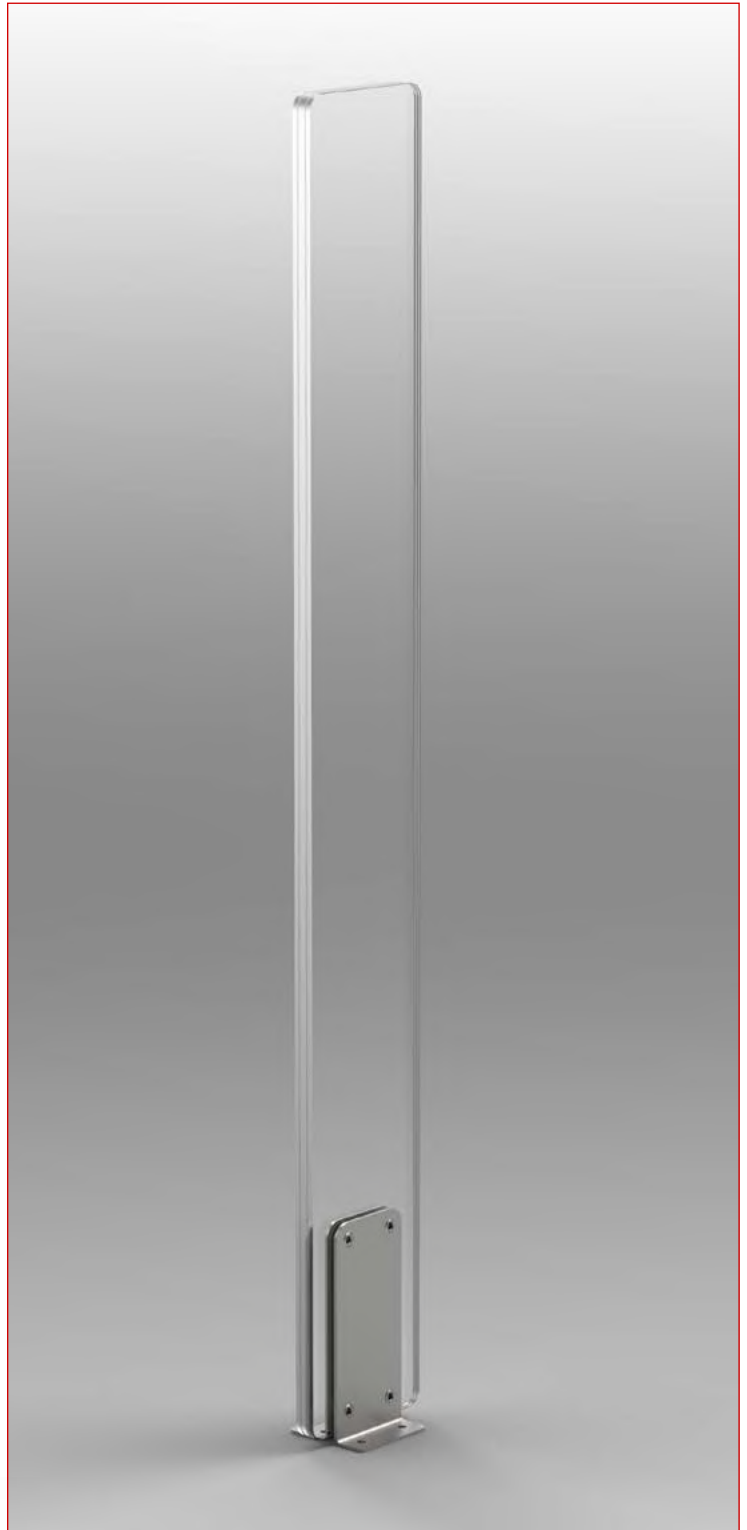

Compatible with all of our antennas and other manufacturers' systems

**The best tool against booster bagging
with trolley-filter**



Hyperguard 24cm

General Info	
Family	Metalguard
Size	24cm
Type	metal detection

Recommendation	metric	imperial
Max Distance	3m	118in
Dimension		
Height	1,51m	59in
Width	0,24m	9.4in
Depth (thickness)	0,011m	0.43in
Approx. weight	13,6kg	30lbs

Electrical Requirements		
PSU	from control box	
Power Consumption	NA	
Operating Temp.	0 - 40 °C	32 - 104 °F

Other	
Antenna Safety	CB, UL/cUL
Emissions Safety	FCC/IC, CE
Materials Used	Steel bottom, plexi body

*detection distance may vary, depends on **environment** and **tag type**.

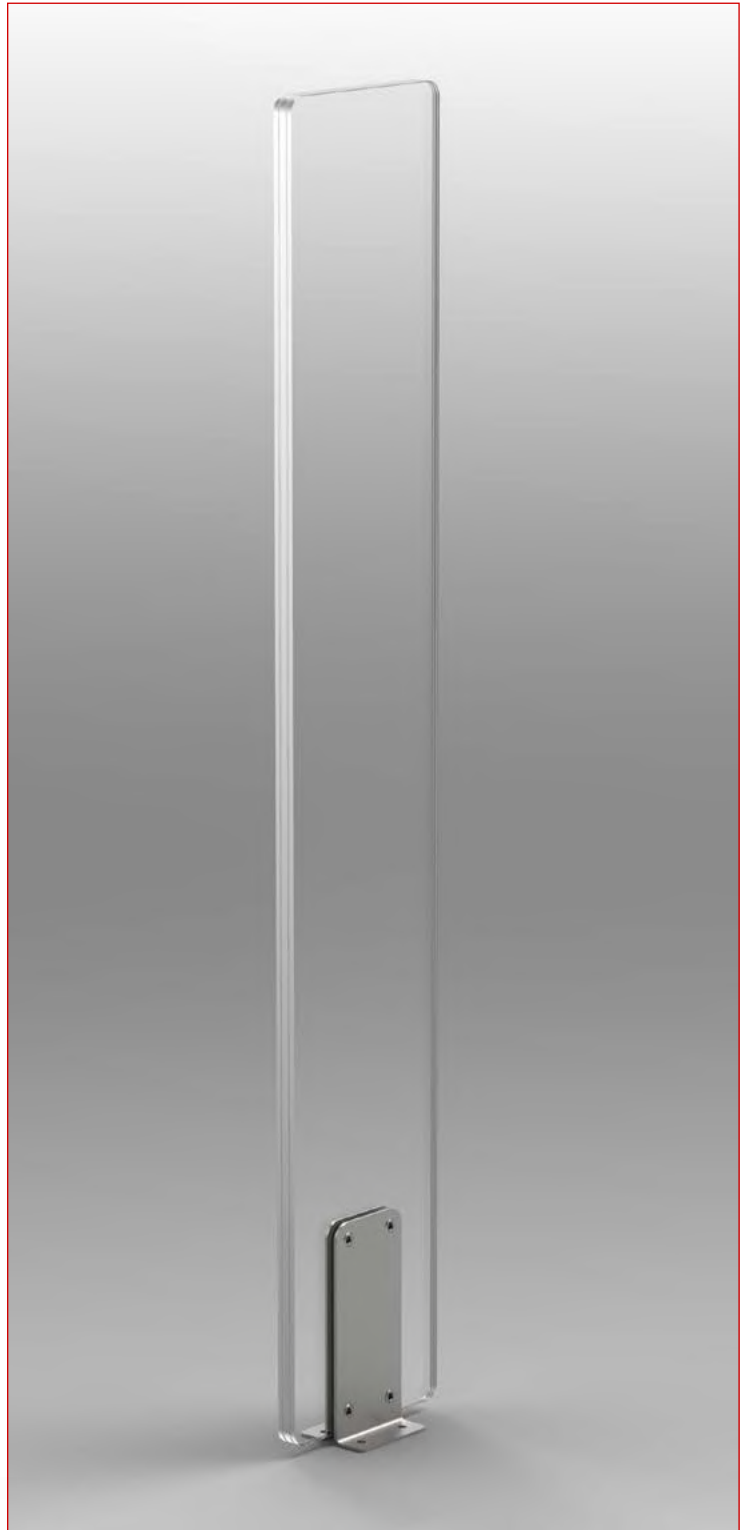

Compatible with all of our antennas and other manufacturers' systems

**The best tool against booster bagging
with trolley-filter**



drinkspector

for RF and AM systems

AWARD WINNING PROTECTION FOR TRADITIONAL HIGH THEFT BOTTLED DRINKS. INNOVATIVE AND ALMOST IMPOSSIBLE TO REMOVE.



DRINKSPECTOR

Drinkspector™ is 100% tamper-proof and cannot be removed by force after installation. Utilising a flexible two piece design and through the use of the optional bottle cap you can completely prevent the opening of all bottles in store.

Drinkspector™ can provide protection for almost all of the bottles being used today in the retail environment. Extremely robust, it is capable of withstanding product attacks of up to 100kgs in pull force.

Drinkspector™ is a deceptively simple solution to what is often viewed as complex and expensive retail problem. Installation takes but a second; reduction in theft rates is immediate, delivering an instant improvement in the bottom line. Dependent upon theft rates ROI can be achieved in as little as 3 months making the Drinkspector™ one of the best valued retail theft prevention devices available today.

KEY FEATURES:

- Simple two piece design
- Tamper proof
- Repels pull force attacks of up to 100kg
- Market leading 5 year warranty on locking mechanism
- Compatible with your existing RF or AM security system



PRODUCT

Product #	Description
8.2 MHz RF Technology	
P0700296	Drinkspector 8.2 MHz RF set - tag and cap - Red colour
P0700036	Drinkspector 8.2 MHz RF tag only - Red colour
P0700209	Drinkspector 8.2 MHz RF tag only - Grey colour
Dual System - RF and AM	
P0700038	Drinkspector Dual RF+AM - Red colour
P0700245	Drinkspector Dual RF+AM - Black colour
AM Technology	
P0700297	Drinkspector AM set - tag and cap - Red colour
P0700035	Drinkspector AM tag only - Red colour
P0700244	Drinkspector AM tag only - Black colour
Other	
P0700040	Drinkspector cap only



RF accessories

deactivators, detectors and others

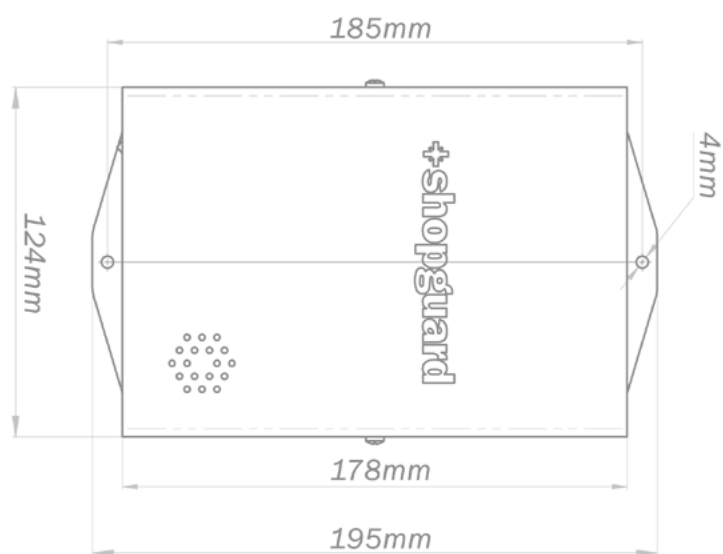
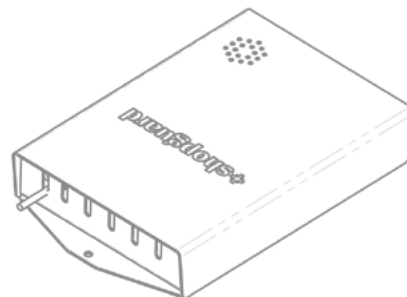
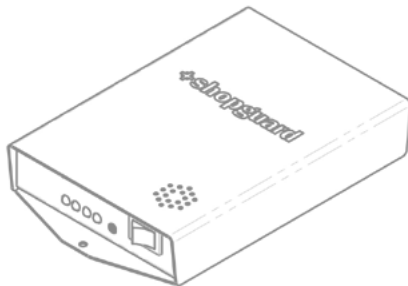

Photo	Description	Part #
 A black, rectangular, textured pad with a red and black braided cable attached to one side.	RF Deactivator pad with interlock <i>(recommended accessory: fixed lower loop for NCR scanners)</i>	P0200166
 A grey handheld device with a handle and a red 'shopguard' logo on the side.	RF Handheld detector and deactivator <i>best accessory for security personnel</i>	P0201043
 A black handheld device with a green LED light on the front.	RF Handheld detector	P0200165
 A silver, rectangular active RF tag with a small metal loop on the front.	Active RF tag <i>(recommended service tool)</i>	P0200373

Checkout Lane Manager

Forget the crowded checkout lanes

A study has shown that a minute spent in a queue during shopping is felt two times more. Consumers can be so frustrated that they go elsewhere.

When we talk about the services a shop can offer we mean different components:

number of available parking space, distance from home, traffic, is the consumer served by polite staff, or how much does it take to finally pay for the goods. On average, the last on list causes the most frustration. Our Checkout Lane Manager helps you to avoid frustration and solves the problem with a press of a button.

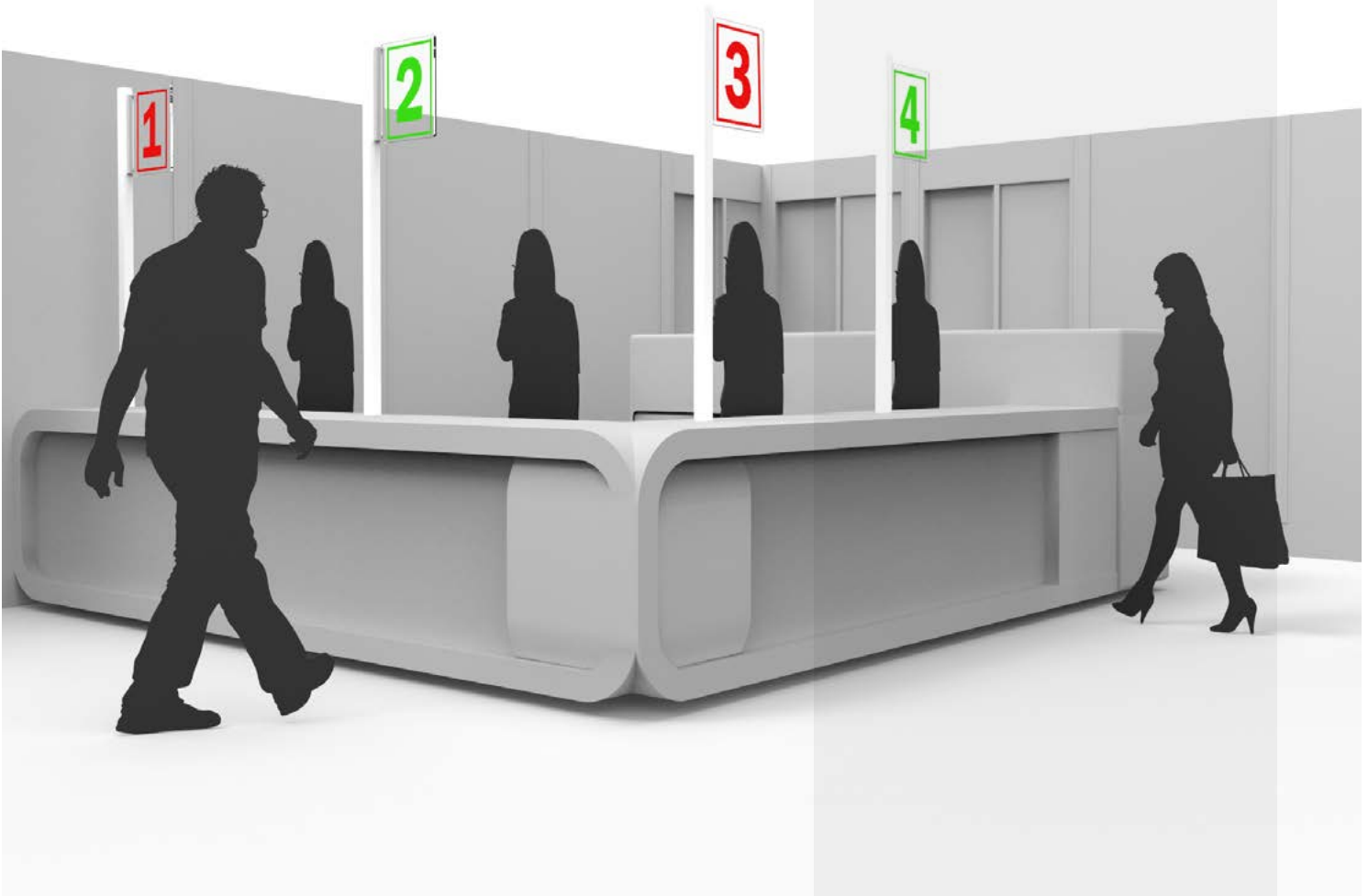



Checkout Lane Manager



Product Features

- Dedicated buttons to open or close a cash register
- Optional buttons for promotions and information
- Easy installation
- Optionally switches on and off label and tag deactivators
- Up to 6 or 8 checkouts can be operated with a single central control unit

Benefits

- Gives straightforward info on which cash register is open
- Avoids long and crowded queues that deter consumers
- Comfortable and efficient for both shoppers and sellers
- Creates a positive attitude that eliminates negative experiences
- Saves time and boosts sales
- Visible and audible channel to communicate promotions and additional info



LABELS AND TAGS

Paper labels, hardtags, spider tags, inktags, pencil tags, glass-tags, bottle tags...

you name it, we have it.

For most scenarios we provide the most innovative and technically advanced products.

Electronic Article Surveillance (abbreviated as EAS) tags and labels are always attached to FMCG items. We offer cost-effective products to both AM and RF systems regardless the brand you use at your doors and aisles.

Contact us for further info
sales@shopguard.com



Your global retail advisor

we make your store smart

